

# DTS 1500

The DTS 1500 is a variation of the DTS 1350. The bearing housing is larger and has more mounting options. The DTS 1500 is a cantilever mount spindle that is intended primarily for tracing forms into grinding wheels. The DTS 1500 is compact, rigid and powerful enough to handle superabrasive applications. This model is intended to accommodate diamond rolls up to 4 inches (100 mm) in diameter and ½ inch (13 mm) wide.

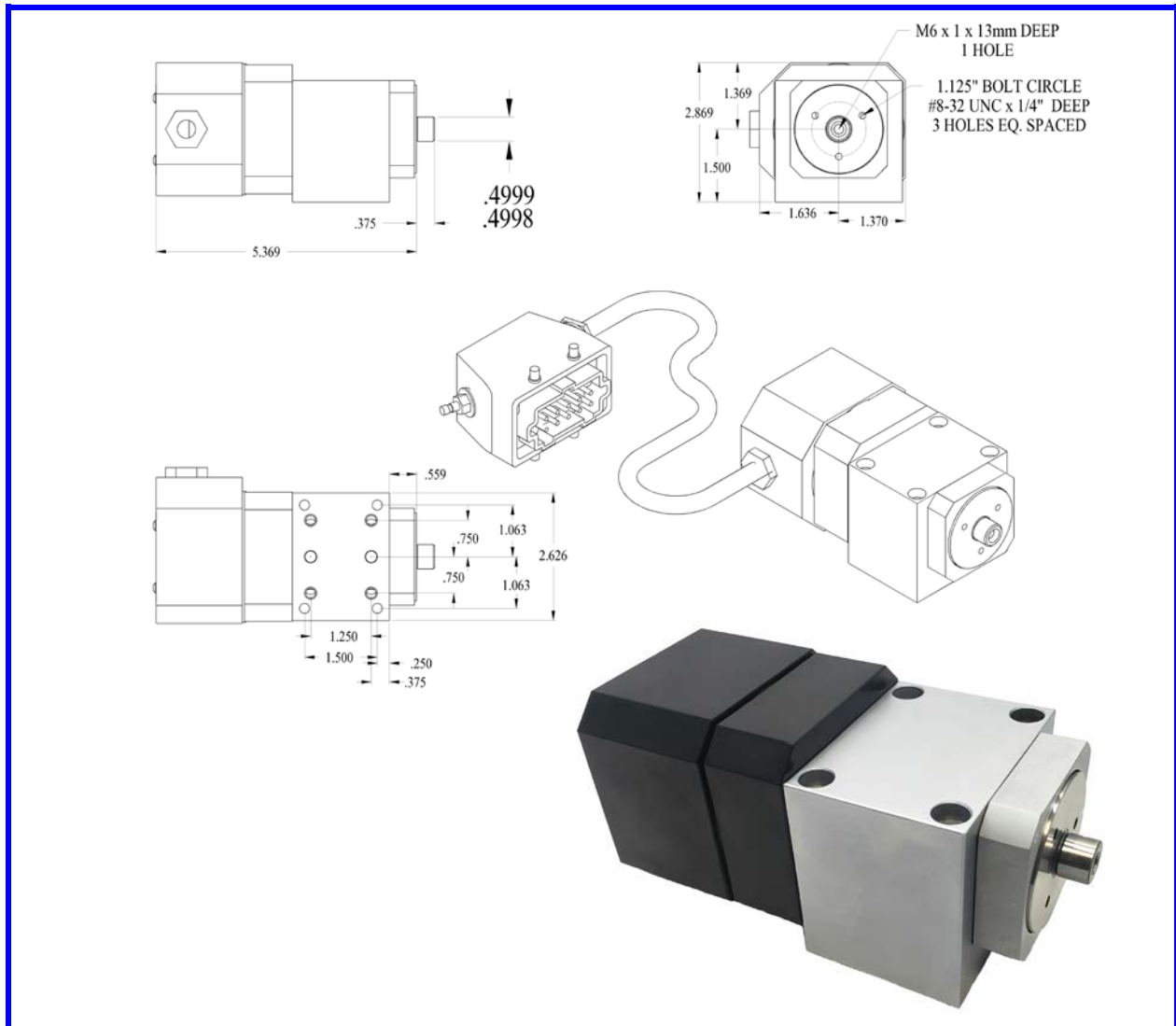

**G II Solutions, Inc.**  
 201 Bank Street  
 P.O. Box 428  
 Central, SC 29630

Phone: 864.639.6605  
 Fax: 864.639.4056  
 E-mail: [info@giisolutions.com](mailto:info@giisolutions.com)  
 Web Site: [www.giisolutions.com](http://www.giisolutions.com)